

# Dakar

design enzo berti

70 (27,6")

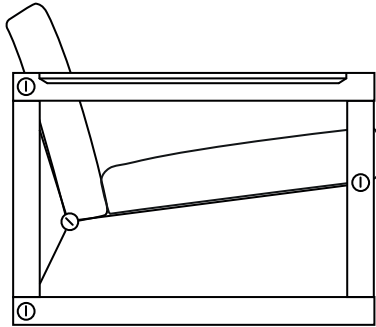

81 (31,9")

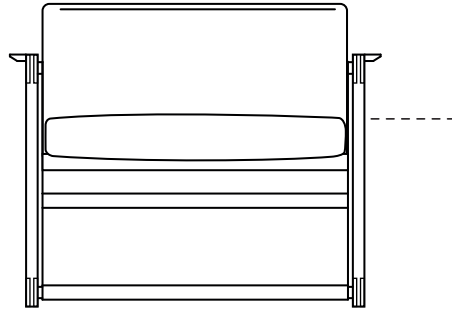

81 (31,9")

44 (17,3")

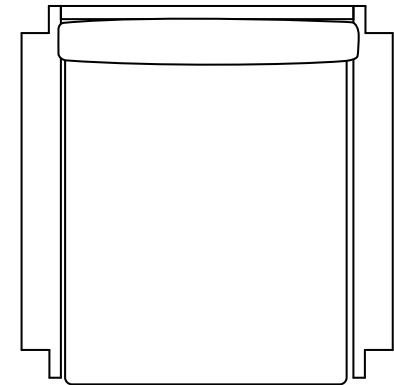

**VER**DESIGN

*hand* MADE  
IN ITALY  
www.verdesign.it

verdesign s.r.l.  
via Pordenone 57, 33070, Brugnera, Pn - Italia  
c.f. / p.iva 01708000938, rea PN98144  
tel/fax +39.0434.627503 - info@verdesign.it

# Dakar tech brief

<b>1. Struttura</b>	Multistrato di pioppo, colla vinilica e con totale assenza di formaldeide. Molleggio su lastra di cuoio con tubolari di acciaio cromato.	<b>1. Structure</b>	Poplar plywood, vinyl glue and formaldehyde-free. Suspensions on hard leather support with chromed tubular stainless steel.	<b>1. Structure</b>	Panneau multicouche de peuplier, colle vinylique et avec totale absence de formaldéhyde. Suspension sur plaque de cuir sellier avec tubulaires en acier chromé.
<b>2. Imbottiture</b>	Poliuretano espanso a densità differenziata con rivestimento esterno in misto piuma d'oca bianca sterilizzata (50%) e fibra di poliestere, con compartimentazione interna.	<b>2. Padding</b>	Polyurethane foam with differentiated density and covering with a mix of white goose sterilized feathers (50%) and polyester fiber, with internal partitioning.	<b>2. Rembourrage</b>	Mousse de polyuréthane à densité différenciée avec revêtement extérieur en mixte de plume d'oie blanche stérilisée (50%) et fibre de polyester, avec partitionnement interne.
<b>3. Cuciture</b>	In filo di poliestere ad alta resistenza, realizzate di serie nello stesso tono del rivestimento. Possibile realizzazione con toni diversi, senza sovrapprezzo.	<b>3. Stitching</b>	In high resistance polyester thread, as a standard manufactured in the same shade of the cover. Different shades are possible, without surcharge.	<b>3. Coutures</b>	En fil de polyester à haute résistance, fabriqué en standard dans le même ton du revêtement. Possible réalisation avec des tons de couleur différents, sans surtaxe.
<b>4. Rivestimenti</b>	Completamente sfoderabili. Cuscini con tessuto jacquard antiscivolo.	<b>4. Covers</b>	Entirely removable. Cushions with anti-slip jacquard fabric.	<b>4. Housses</b>	Complètement déhoussables. Coussins avec du tissu jacquard antiglisse.
<b>5. Resistenza al fuoco</b>	Tutte le gomme, le piume e le fibre impiegate sono esclusivamente ignifughe.	<b>5. Fire resistance</b>	All used foams, feathers and fibers are exclusively fireproof.	<b>5. Résistance au feu</b>	Toutes les mousses, les plumes et les fibres utilisées sont uniquement ignifuges.
<b>6. Telaio</b>	Legno massello di noce nero ("canaletto"), con feltrini antigraffio. Finitura con vernici all'acqua con effetti "soft touch", "anti reflex" e "anti fingerprint".	<b>6. Frame and coffee table</b>	Solid black walnut wood ("canaletto"), with scratchproof felts. Water based coatings with "soft touch", "anti reflex" and "anti fingerprint" effects.	<b>6. Cadre</b>	Bois massif de noyer noir ("canaletto"), avec feutres anti-rayures. Finition avec peintures à base d'eau avec effets "soft touch", "anti reflex" et "anti fingerprint".
<b>7. Imballo</b>	Sacco in polietilene, nylon a bolle d'aria e scatola in cartone rinforzato. Adatto per trasporto terrestre, marittimo e aereo.	<b>7. Packaging</b>	Polyethylene bag, bubble nylon and reinforced cardboard box. Suitable for land, sea and air freight.	<b>7. Emballage</b>	Sac en polyéthylène, nylon à bulles et boîte de carton renforcé. Approprié pour transport terrestre, maritime et aérien.

